

For Residential and Commercial Applications

Job Name _____
 Job Location _____
 Engineer _____
 Approval _____

Contractor _____
 Approval _____
 Contractor's P.O. No. _____
 Representative _____

SunStat® Core

Electric Floor Heating Thermostat

This all-in-one thermostat includes a built-in relay to control 120 or 240 VAC floor heating systems and a GFCI to improve safety. The SunStat Core controls the floor temperature with input from the included floor sensor.

Specifications

Literature	IOM-ST-Core, ES-ST-Core
Operation Voltage	120/240 VAC, 60 Hz, 3 watts
Maximum Load	15 amps resistive
Maximum Power	1800 watts at 120 VAC 3600 watts at 240 VAC
GFCI	Class A (5 milliamp trip)
Dimensions	4-5/8" H x 2-19/20" W x 1-13/20" D (118 x 75 x 42 mm)
Enclosure	White PVC plastic, NEMA type 1
Ambient conditions	32 to 86°F (0 to 30°C), <90% RH non-condensing
Floor Sensor	Thermistor, 10k NTC type, 300 V jacketed cable, 15' long



Floor Sensor



SunStat Core

Features

- Floor temperature control
- Thin profile
- Simple temperature adjustment
- Built-in GFCI
- Control 120 or 240 VAC electric floor heating systems



UL Listed under UL 943, UL 873, UL 991
 Listing file number E365015.

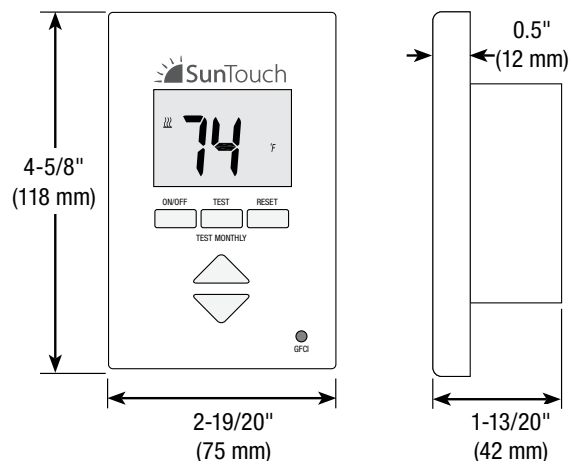

⚠ WARNING

This Engineering Sheet is not intended to provide full installation instructions and safety information. In order to avoid property damage or injury, please refer to the complete installation manual and product safety information provided with the product.

Product Options

Qty	Description	Model#	Order#
	SunStat Core Thermostat	500825-SB	81019083
	Extra Floor Sensor (optional)	500110	81009178

SunTouch product specifications in U.S. customary units and metric are approximate and are provided for reference only. For precise measurements, please contact SunTouch Technical Service. SunTouch reserves the right to change or modify product design, construction, specifications, or materials without prior notice and without incurring any obligation to make such changes and modifications on SunTouch products previously or subsequently sold. Refer to the owner's manual for warranty information.

SunStat Core Application Examples

Typical Wiring for SunStat Core with one mat or cable (120/240 VAC).

Dedicated 120 or 240 VAC, 20-amp (maximum) circuit (maximum 15 amp load through SunStat control)

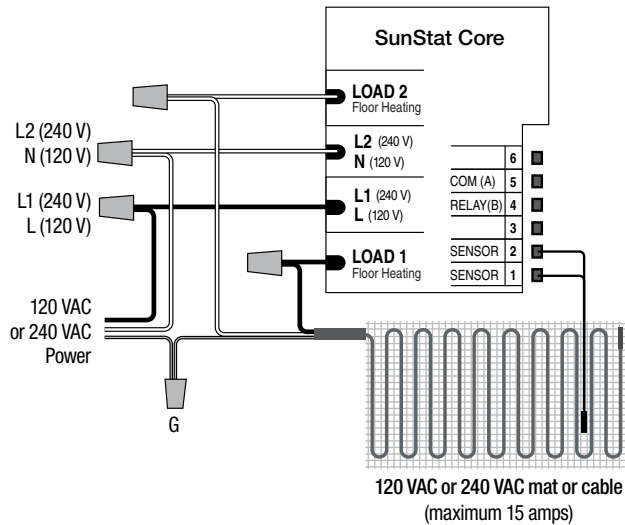

Typical Wiring for SunStat Core with multiple mats or cables (120/240 VAC).

Dedicated 120 or 240 VAC, 20-amp (maximum) circuit (maximum 15 amp load through SunStat control)

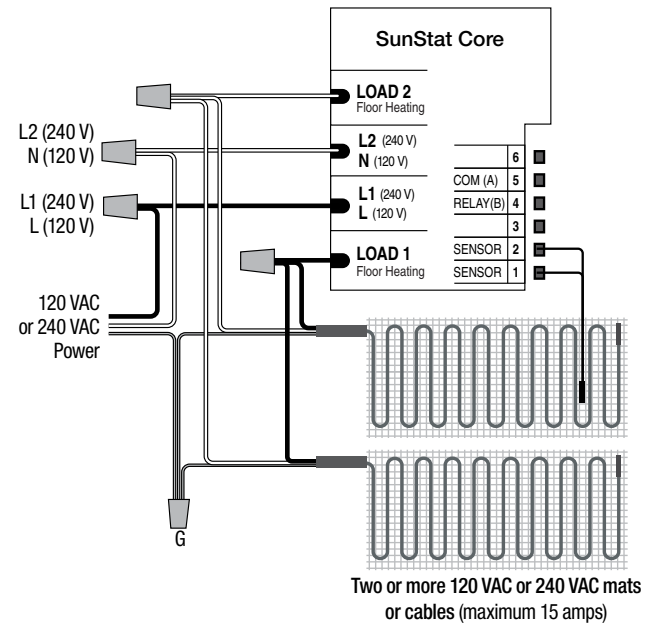

Electrical Wiring Diagram for SunStat Core with SunStat Relay C3 (120/240 VAC). Up to 10 SunStat Relay C3's can be connected to expand the area controlled by a single SunStat Core.

Dedicated 120 or 240 VAC, 20-amp (maximum) circuit (maximum 15 amp load through SunStat control)

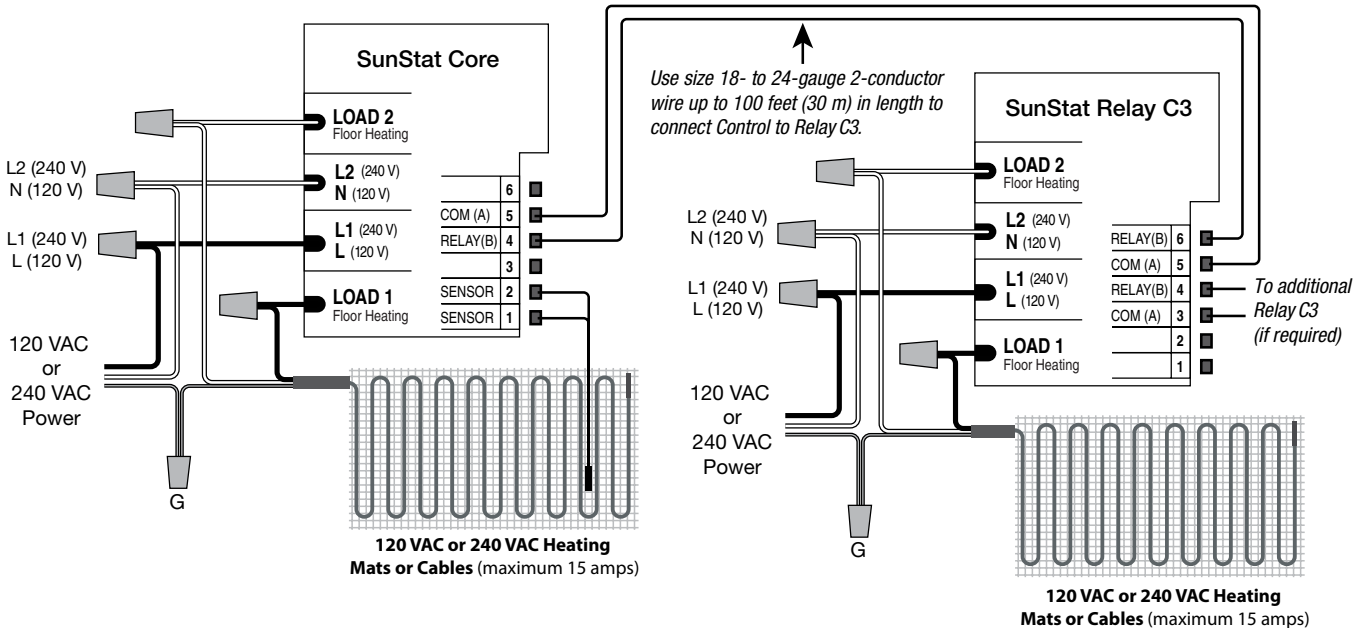

USA: T: (888) 432-8932 • F: (417) 831-4067 • SunTouch.com

Canada: T: (905) 332-4090 • F: (905) 332-7068

Latin America: T: (52) 81-1001-8600 • SunTouch.com